

## 產品特點 Features

◇此系列真空產生器是直通設計，在輸送物料時無堵塞且無需維護，適用於輸送顆粒、粉末及塊狀物體等。這些產生器有不同規格孔徑，最高流量孔徑可達38mm。

☆The vacuum pump has a straight through design, hence they are non-clogging and maintenance free, and it is particular for transferring particles, powders. High flow can be achieved with in line bore sizes up to 38mm.

## 技術規格 Specifications

最大真空度Max.vacuum Level	-35kPa
最大真空流量Max.vacuum flow rate	5610l/m
供氣壓力Air supply pressure	4-6bar 最大7bar 4-6bar Max.7bar
供氣類型Air supply type	乾燥的壓縮空氣Dry Compressed air



## 訂購碼 How to Order

### FACPF 2-3 - AL

①

②

#### ① 規格 Model

2-3	7-6
3-3	15-3
5-6	15-6

#### ② 材料 Material

AL-鋁
AL-Aluminum
SS-不銹鋼
SS-Stainless steel

## 應用事例 Applications

- ◇真空輸送物料
- ◇清除各種造紙及原料加工邊綫
- ◇輸送小麥、玉米等穀物
- ◇輸送洗衣粉和塑料粉
- ◇去除鑽孔工序中的碎片
- ◇去除發動機配件等研磨工序中的粉末
- ☆ Transferring materials
- ☆ Seledge removal intrimming operation
- ☆ Convy wheat, corn
- ☆ Transfer powder detergent and plastic powder
- ☆ Chip removal in drilling operation
- ☆ Powder removal in grinding operation

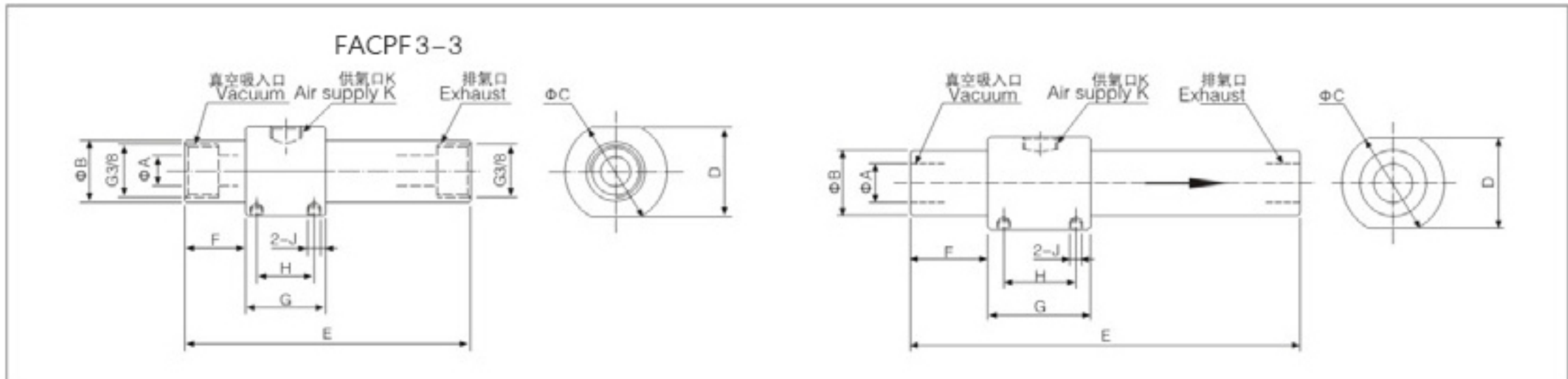
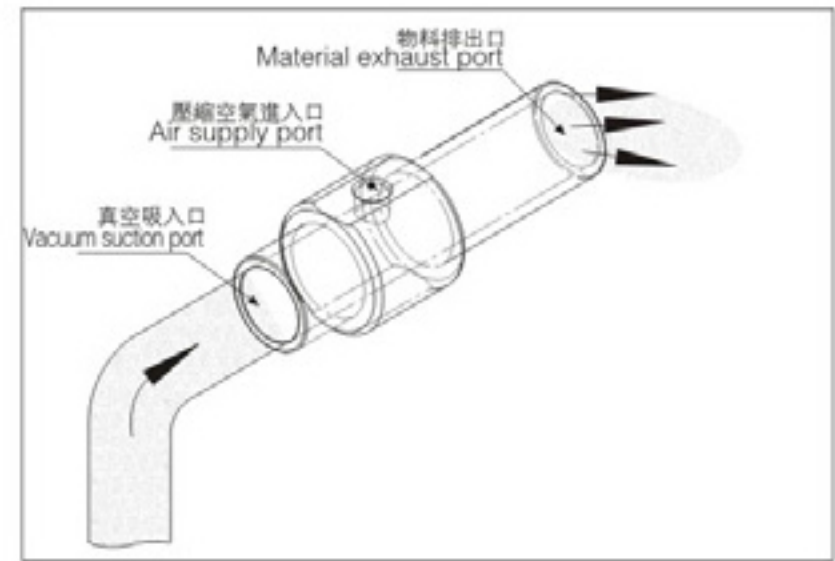

型號 Model	尺寸規格 Dimension									
	ΦA	ΦB	ΦC	D	E	F	G	H	J	K
FACPF2-3	6.5	18.5	32	30	89	19	25	18	M4	G1/8
FACPF3-3	9.5	18.5	32	30	89	19	25	18	M4	G1/8
FACPF5-6	12.5	24	38	34	140	25.5	32	23	M4	G1/4
FACPF7-6	19	32	50	45	190	38	50	35	M6	G3/8
FACPF15-3	38	49.6	69	65	205	40	60	42	M6	G3/8
FACPF15-6	38	49.6	69	65	205	40	60	42	M6	G3/8

## FACPF系列真空流量(l/m)、真空度(-kPa)、耗氣量(l/m) FACPF Series Vacuum flow(L/m)、Vacuum level(-kPa)、Air Consumption(L/m)

型號 Model	空氣速度 Air velocity	真空流量 Vacuum flow l/m	真空度 Vacuum level -kPa	空氣消耗量(l/m) Air consumption(l/m)	
	ft/s			2.8bar	5.5bar
FACPF 2-3	485	295	26	85	160
FACPF 3-3	328	425	16	95	170
FACPF 5-6	361	870	35	395	680
FACPF 7-6	325	1825	28	790	1365
FACPF15-3	223	4400	9	405	695
FACPF 15-6	270	5610	9	790	1365